

Invisible Zipper

12.310

Page 1



SEW-lutions Guidelines

Your Guide
to
Successful
Sewing

© 2008 Sewing & Craft Alliance
Permission is granted to
educators and retailers to
reproduce these publications
as-is as a handout for
educational purposes only.
They may not be altered,
changed or added to in any
manner. No commercial or other
use, distribution, or
reproduction is permitted.

Get free projects and
more SEW-lutions
Guidelines at
www.sewing.org



Now you see it, now you don't! An invisible zipper features no stitching and no zipper showing at all on the finished application—the opening simply looks like a seam, with the exception of the tiny color-matched tab use to open the zipper.

An invisible zipper is different from a standard zipper, but can be substituted for a regular zipper in all placket applications.



Foot News

To apply an invisible zipper, you will need a special foot sold by the zipper manufacturer. It is possible to apply the zipper using a conventional adjustable zipper foot, but the results may not be as successful.

Most invisible zipper feet come with assorted shanks to adapt to various machine models. Also, check with your machine dealer for a brand-specific presser foot.

The foot has deep angled grooves on the underside that ride over the zipper teeth and help hold them upright during the stitching process for close-to-the-coil sewing. This is the secret to a successful application.

Preparation

An invisible zipper coil is rolled and most manufacturers recommend lightly pressing the coil to unroll it for easier application. Since coils are synthetic, watch the iron temperature to avoid melting.

Unlike conventional zippers, an invisible zipper is applied open and with the entire seam open where it will go. Both the remainder of the seam and the zipper are closed once the application is complete.

If the seam allowances require a finish of any type, do that before applying the invisible zipper. Options include zigzagging, serging or binding.

Zipper Application

Pin the open zipper face down on the right side of the garment with the coil along the seamline and the zipper tape toward the seam edge. The upper end of the zipper coil should be at least 5/8" below the garment upper edge to allow for finishing with a facing or waistband after the zipper is applied.

Place the right groove of the presser foot over the unrolled coil and stitch from the top down to the zipper slider; backstitch to anchor (1).

Pin the opposite side of the zipper to the remaining garment section with the coil along the seamline, and being careful not to twist the zipper. Match the garment upper edges and/or any crosswise patterning. Fit the left groove of the foot over the coil and stitch the zipper in place as for the previous side (2).

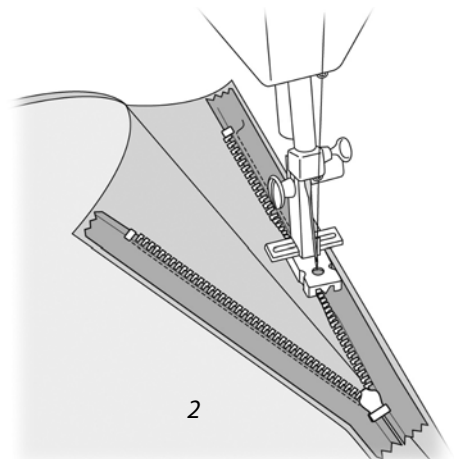
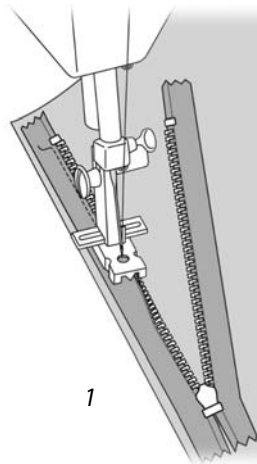

Use the needle position adjustments on your sewing machine to place the needle as close to the zipper coil as possible, but being sure the stitching will not catch the coil. If the coil is caught during the stitching process, the zipper will not work and restitching will be required.

To use a conventional zipper foot to apply an invisible zipper, position the needle to the side of the foot and manually unroll the coil as you stitch as close as possible to the zipper teeth following the directions above. Some machines have buttonhole feet with grooves, similar to the invisible zipper foot, which can also be used for installation.

Finishing

Once both sides of the zipper have been stitched, change to a conventional adjustable zipper foot to finish stitching the garment seam. Position the needle to the right side of the foot.

Close the zipper and pin the seam together below the zipper. Carefully lower the needle into the fabric at the end of the previous stitching line, slightly above and to the left of it (3). Stitch the remaining seam closed.

Stitch the free ends of the lower zipper tape only to the seam allowances to hold it in place.

Finish the upper edge of the zipper opening according to the pattern instructions, applying a facing, waistband, binding, etc. ■

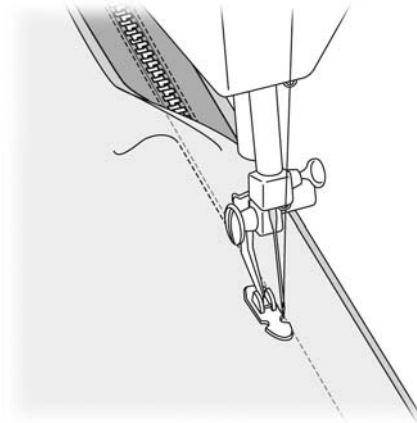

3

For more information on other zipper applications, see Guidelines #12.155 Centered Zipper and 12.250 Lapped Zipper.